



**COMPACT
LIGHT-WEIGHT
EMISSION FREE**

 **cube**

**MOBILE TIRE SERVICE.
MOBILE ENERGY SOLUTIONS.**



SERVICING FUTURE MOBILITY. MOBILE!

- Requires just 1.1m² of floor space
- Lightweight
- Massive cost savings on idling engine
- No disturbing noise or fumes
- Remote monitoring, software updates and troubleshooting
- Cold climate? Doors closed – full functionality
- Specifically designed for mobile service market
- Compact dimensions and modular design allow for flexible installation
- Temperature controlled 48V Lithium powerbank starting from 2.6 kWh
- Works on a wide range of tire sizes
- Guarantees workshop quality on your customer's driveway
- Easy to (de)install (**no drilling required**)
- Easy to operate
- NIOSH recommended working height
- AC/DC & 12V DC/DC charging – solar optional
- Service friendly
- The heart of your mobile service platform
- Bring the WOW factor to your customer
- Preferred choice of various international car & tire manufacturers and their networks
- Designed, engineered & manufactured in The Netherlands

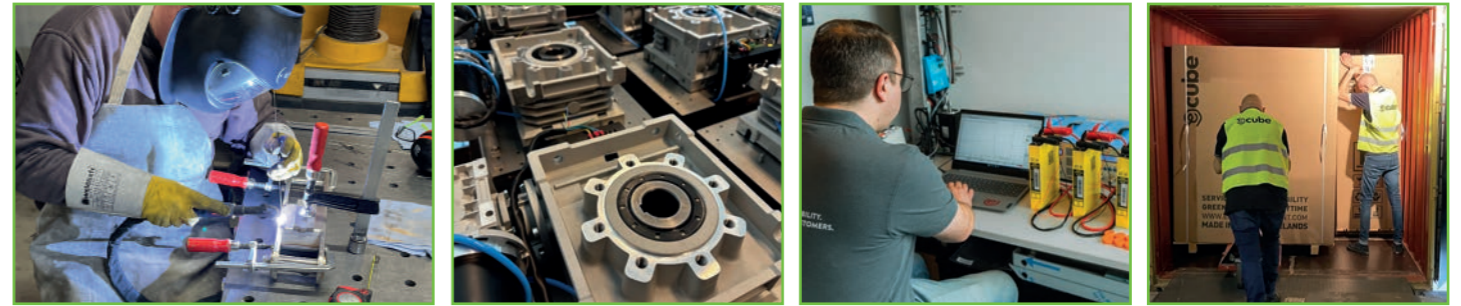

YOU ARE IN-CONTROL TECHNOLOGY (INTERNATIONAL PATENTS PENDING)
One machine! Two operation methods - **LEVER OR LEVERLESS!**



As mobile tire servicing and mobile car servicing become more and more popular throughout Europe, North America and Asia, innovation in how these modern workshops on wheels operate must keep up. Our ecube does just that. It is **emission free, lightweight, compact** and it benefits from a **modular design** to ensure that ecube **easily fits in any vehicle or trailer**.

With ecube using a minimum of floorspace, it becomes possible to haul more tires, tools and equipment. Thus, ensuring more profitable stops and 'no need to return' service jobs.

As operator, you work in a comfortable environment all year round. ecube uses a temperature controlled lithium battery bank, developed and manufactured in-house. This eliminated fumes and noise pollution that traditional generators are known for. As a result of that you continue to work inside your vehicle, with all doors fully closed, when weather conditions are harsh.

Despite its compact dimensions, ecube makes no compromises on functionality and robustness. It changes tires from **10 to 24 inches** with 40 inches as maximum wheel diameter. We offer a large range of accessories around ecube and upgrades to ecube. Our **in-control system** (international patents pending), making your ecube **both a lever and leverless machine**, is just one of them.

WHY ECUBE'S BATTERY POWERED SYSTEM?

GENERATOR PTO SYSTEM	ECUBE BATTERY SYSTEM
<input checked="" type="checkbox"/>	<input checked="" type="checkbox"/> OPERATOR FRIENDLY
<input checked="" type="checkbox"/>	<input checked="" type="checkbox"/> WORK 'INDOOR' - ENCLOSED PARKING / UNDERGROUND PARKING
<input checked="" type="checkbox"/>	<input checked="" type="checkbox"/> STOP BURNING EXPENSIVE FUEL!
<input checked="" type="checkbox"/>	<input checked="" type="checkbox"/> HIGHLY COMPACT AND EASY TO (DE) INSTALL
<input checked="" type="checkbox"/>	<input checked="" type="checkbox"/> 30% LIGHTER
<input checked="" type="checkbox"/>	<input checked="" type="checkbox"/> CELLS ARE MAINTENANCE FREE FOR THE FIRST 5 YEARS
<input checked="" type="checkbox"/>	<input checked="" type="checkbox"/> INCREASE POWER WHEN YOUR BUSINESS GROWS/TRANSFORMS
<input checked="" type="checkbox"/>	<input checked="" type="checkbox"/> EXTEND YOUR SERVICES - CONQUEST NEW CUSTOMERS
<input checked="" type="checkbox"/>	<input checked="" type="checkbox"/> >3000 CYCLES
<input checked="" type="checkbox"/>	<input checked="" type="checkbox"/> ALLOWING SENSITIVE APPLIANCES TO BE CHARGED/OPERATED
<input checked="" type="checkbox"/>	<input checked="" type="checkbox"/> PURE SINE WAVE INVERTER

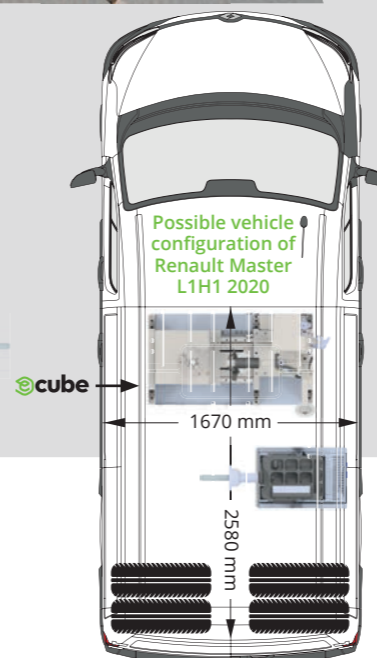
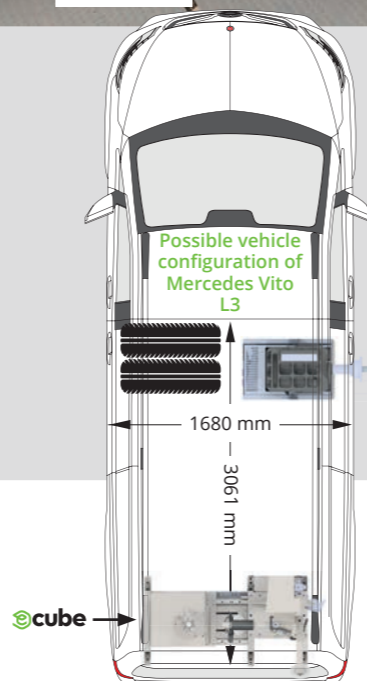
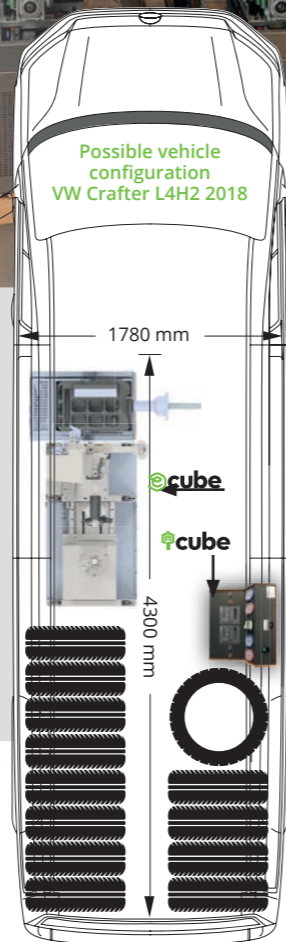
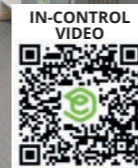
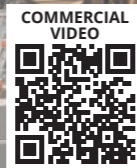

WHATEVER CONFIGURATION, WHATEVER VEHICLE OR TRAILER
ECUBE - DOES FIT!



FEATURES

- **WEIGHT:** 280 KG (tire changer/lower frame with compressor)
- **MAX. HEIGHT:** 1835 MM
- **FLOORSPACE:** 1.1 M²
- **PERFORMANCE:** UP TO 80 TIRES (FULLY SERVICED WHEN 100% CHARGED)

INCLUDES

- 10 - 24" (max. wheel diameter 43")
- 48V / 5.4 kWh temperature controlled
- AC/DC, DC/DC charging
- 2 helper arms and **IN-CONTROL** operation (international patents pending)
- 40L aluminum tank (Certified)
- Industrial compressor 8 - 10 Bar
- **2000W** / 6000W industrial inverter
- Includes soft start and turtle mode kit
- Includes touchscreen and camera kit (remote support, operator videos, control switch system test, customized screen)
- PCL digital inflating system
- Adjustable turntable height
- Tire lever, elube and more

OPTIONAL

- Detach remote foot controller
- Solar charging

BALANCER

- 2D Motorized model with Haweka Centering (up to 26")
- Weight (including accessories): 50 KG
- **Optional:** Laserline and auto positioning

POWERBOX

- Weight: starting from 48 KG
- As we design and manufacture our own power-boxes there's always a power & air solution that meets your specific requirements. This relates to both performance and charging needs.
- Challenge us!**



FEATURES

- **WEIGHT:** 230 KG (tire changer/lower frame with compressor)
- **MAX. HEIGHT:** 1482,6 MM
- **FLOORSPACE:** 1.1 M²
- **PERFORMANCE:** UP TO 40 TIRES (FULLY SERVICED WHEN 100% CHARGED)

INCLUDES

- 10 - 24" (max. wheel diameter 43")
- 48V / 2.6 kWh temperature controlled
- AC/DC or DC/DC charging
- 40L aluminum tank (Certified)
- Industrial compressor 8 - 10 Bar
- 500W industrial inverter installed in battery box (only with AC/DC charging configuration)
- Analogic handheld inflator
- Adjustable turn table height
- Tire lever and elube

OPTIONAL

- Standard helper arm
- Second helper arm with **IN-CONTROL** operation (international patents pending)
- Detach remote foot controller
- Soft start and turtle mode kit
- Touchscreen and camera kit (remote support, operator videos, control switch system test, customized screen)
- PCL digital inflating system
- Solar charging

BALANCER

- Hand spin model with Haweka Centering (up to 26")
- Weight (including accessories): 60 KG
- **Optional:** 2D Motorized model with Haweka Centering (up to 26")

POWERBOX

- Weight: starting from 48 KG
- As we design and manufacture our own power-boxes there's always a power & air solution that meets your specific requirements. This relates to both performance and charging needs.
- Challenge us!**

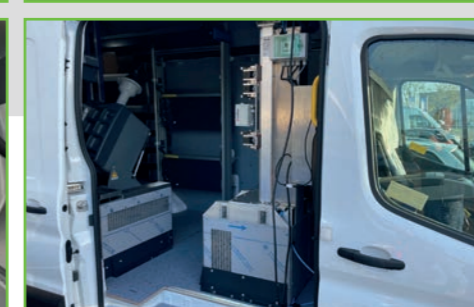
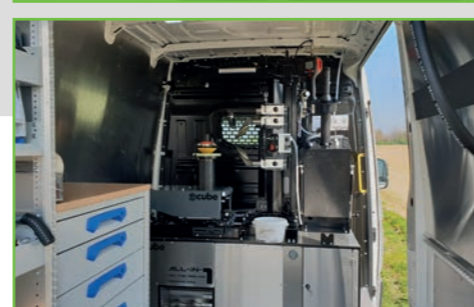
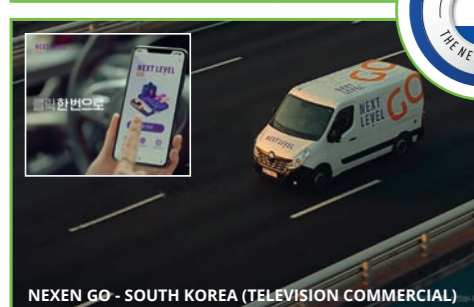
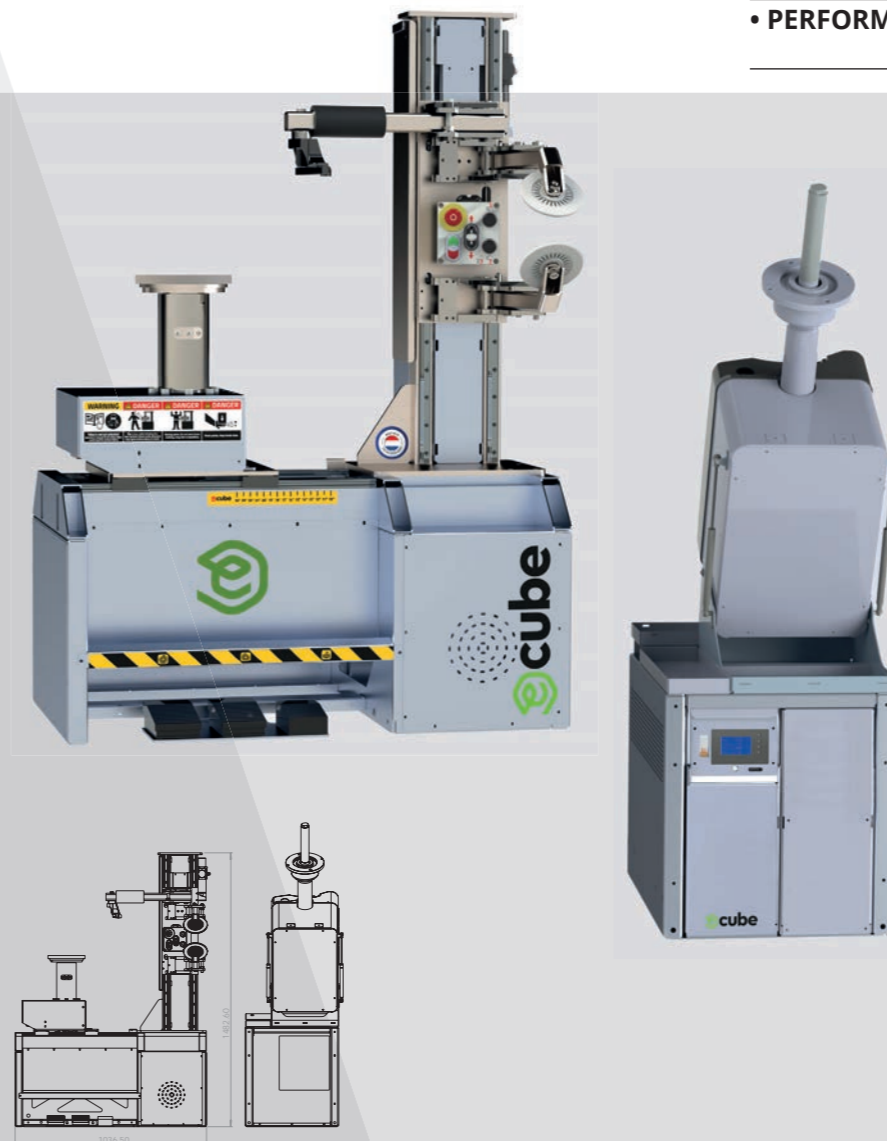

NEXEN GO - SOUTH KOREA (TELEVISION COMMERCIAL)



INVERTER BOX

MAX STANDARD	MAX PERFORMANCE
2000W	6000W
50 / 60 Hz	50 / 60 Hz
110 / 230V	230V

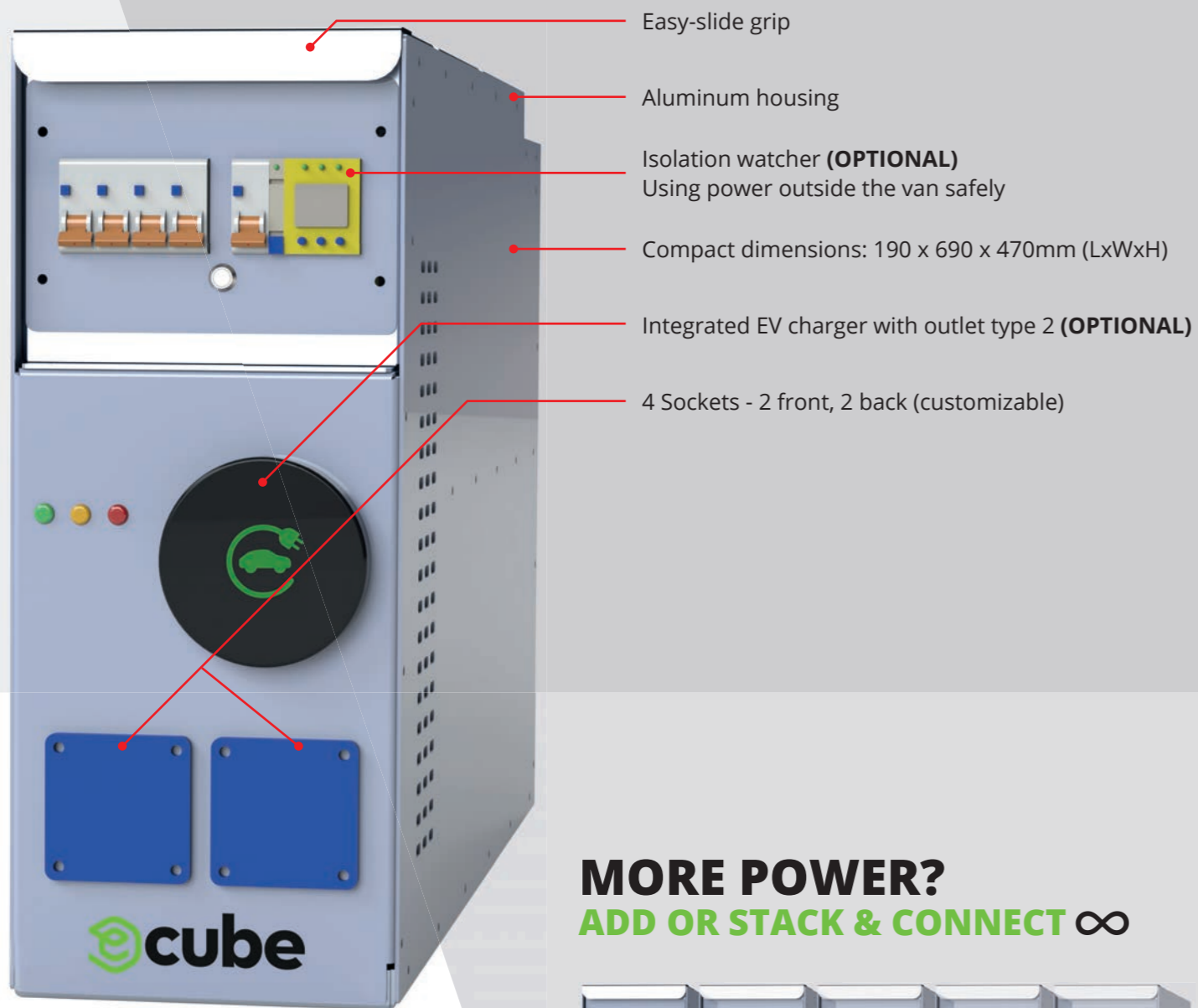

MORE POWER?
ADD OR STACK & CONNECT ∞



BATTERY BOX

STANDARD	EXTENDED
2,6 kWh	5,6 kWh
48V	48V

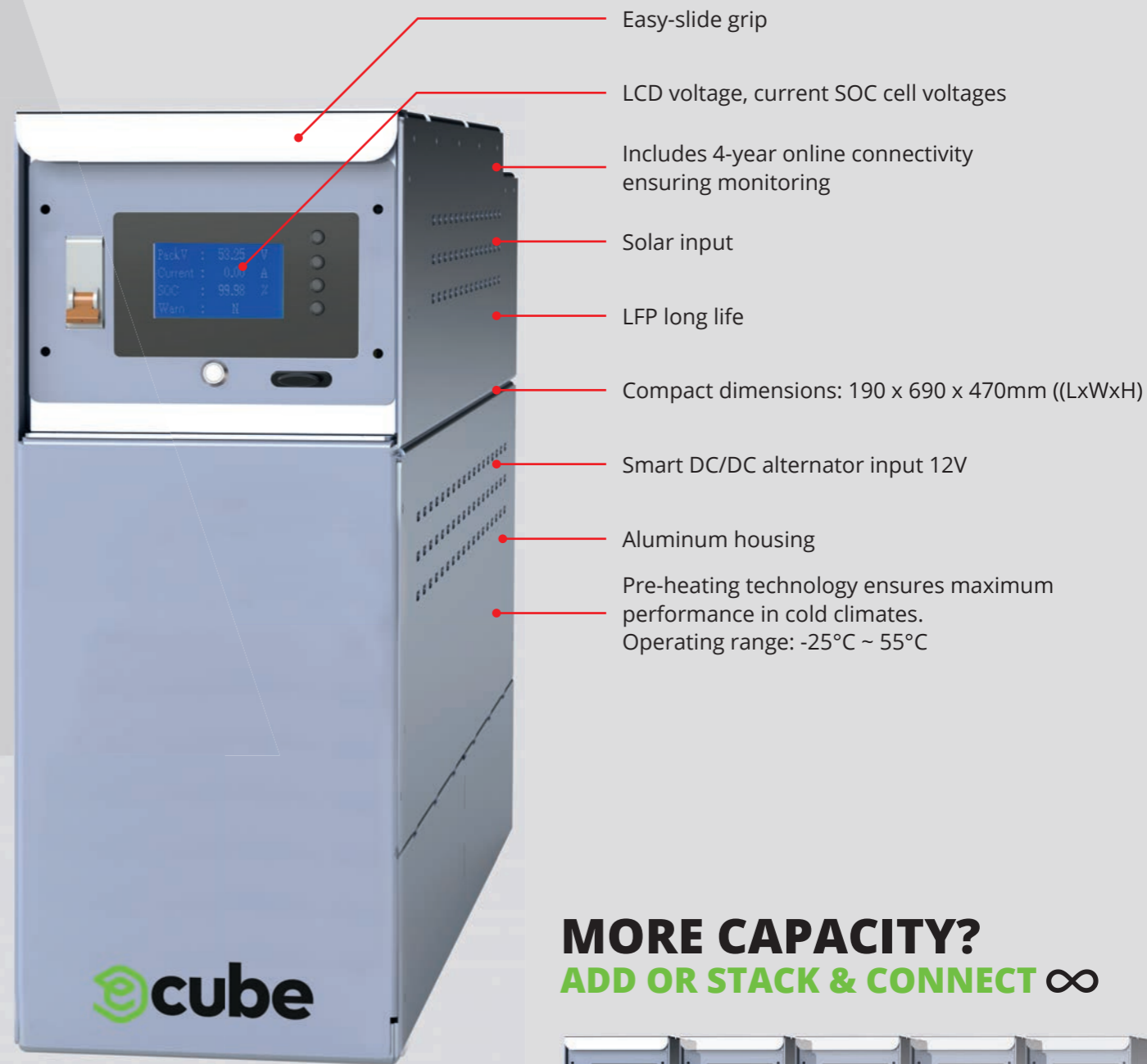

MORE CAPACITY?
ADD OR STACK & CONNECT ∞





TOOLS, LIFTING, CENTERING, LUBRICATION, CHARGING - ACCESSORIES

We offer an ever-growing, comprehensive range of quality tools and accessories which provide you with all you need to be able to grow and manage your mobile business.

Contact us for the full range



**SUPER FLEXIBLE,
ULTRA-THIN & ULTRA-
LIGHT SOLAR PANEL
360W (200 X 100 CM)**



DUAL GAS - VIBRATION RESISTANT AC



Launching ecube's etower and GEN1MTS26

The next, emission free, low noise, all-in-1 mobile tire service solution for bus and (light) truck wheels up to 26". etower includes a high capacity lithium battery bank and benefits from high speed AC/DC, DC/DC and (optional) solar charging. etower also includes a high output, screw compressor that reaches up to 12 bars.

The next, emission free, low noise, all-in-1 mobile tire service solution for bus and (light) truck wheels up to 26"

A fully charged etower ensures 30 wheels being fully serviced (demount/mount/balance). Charging etower from 0-100% costs **less than 5 Euro!** How much fuel do you currently burn per hour? What about maintenance cost and downtime? We think we can do better. In fact we're pretty sure!

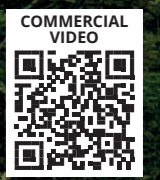
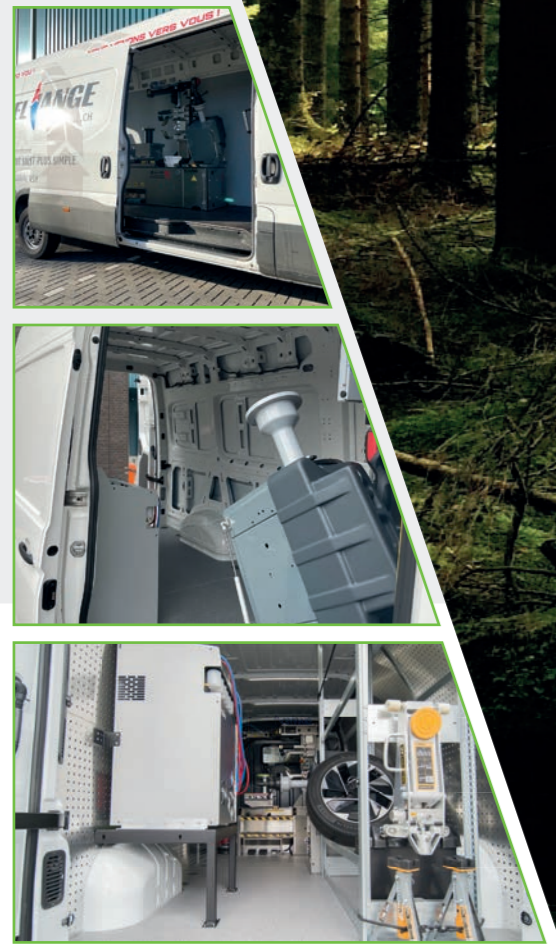

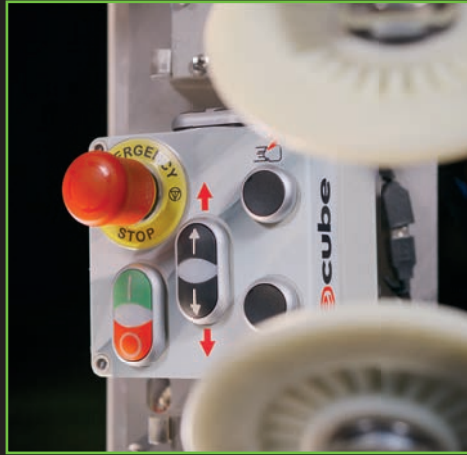

ECUBE'S SUPERIOR ERGONOMICS ALLOWS FOR SIGNIFICANTLY REDUCED FATIGUE AND INCREASED QUALITY AND PRODUCTIVITY.



OPERATING ECUBE IS EASY! WE PROVIDE ONSITE & (LIVE) ONLINE TRAINING SESSIONS TO HELP YOU UNDERSTAND THE INS & OUTS.

Every reasonable effort has been made to present current and accurate information at time of print. However, ecube International BV reserves the right to change product specifications without notice.